

Good



Bad



Ugly



Effective



Getting the Most Out of Presentation Software

Vincent Rhodes, PhD, APR
varhodes@gmail.com
@varhodes





WARNING:

**THIS IS NOT A TYPICAL
PRESENTATION!**

Is PowerPoint Evil ?



IS POWERPOINT A **TOOL?**

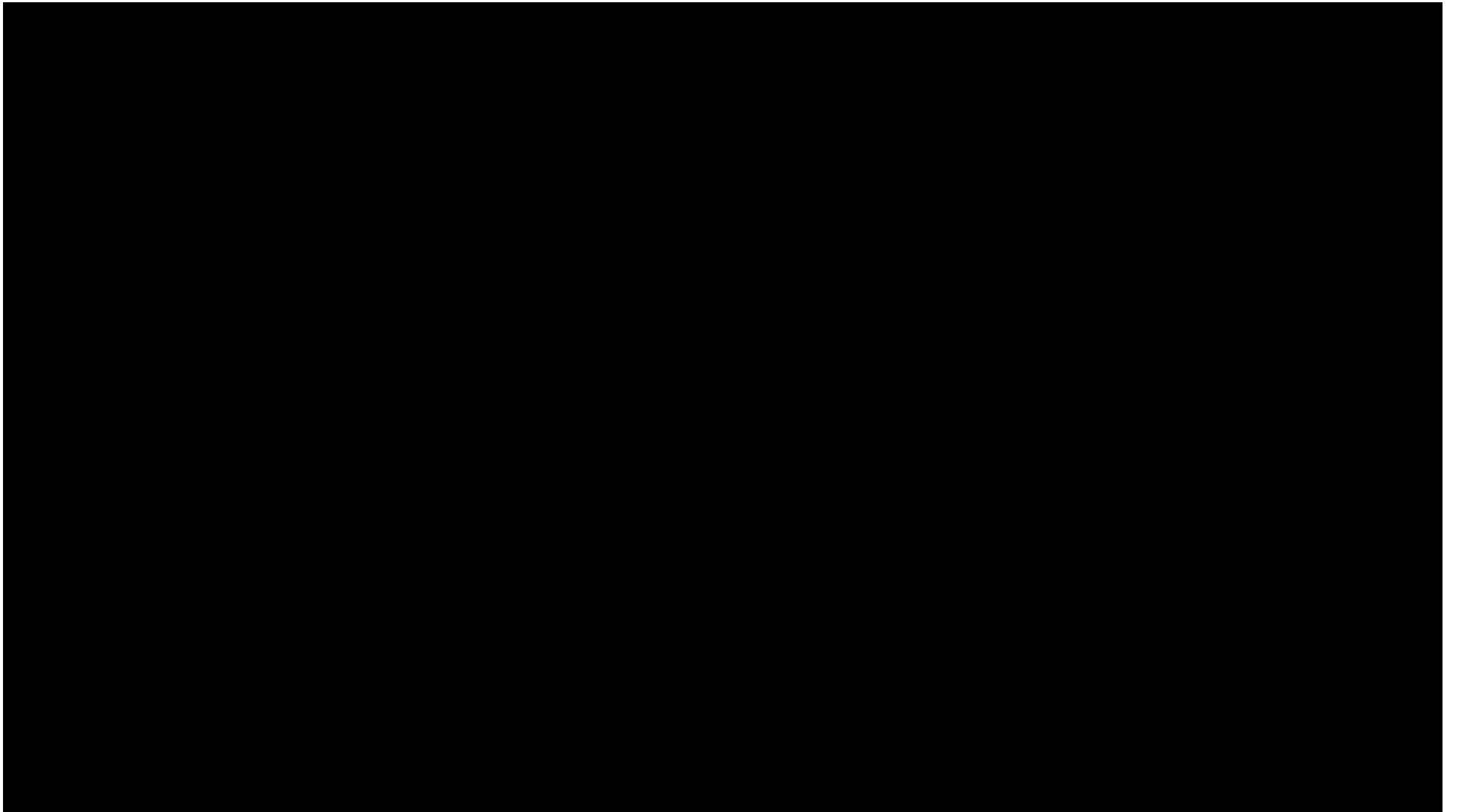



Mount Everest













*conquered
Everest*

1953

Tenzig Norgay &
Edmund Hillary







the speech tells a story



the presentation makes it visual

What Makes Messages Stick?

Unexpectedness

Concreteness

Simplicity

Garr Reynolds, *Presentation Zen* (p. 77)

Always Write the Speech First. Usually.

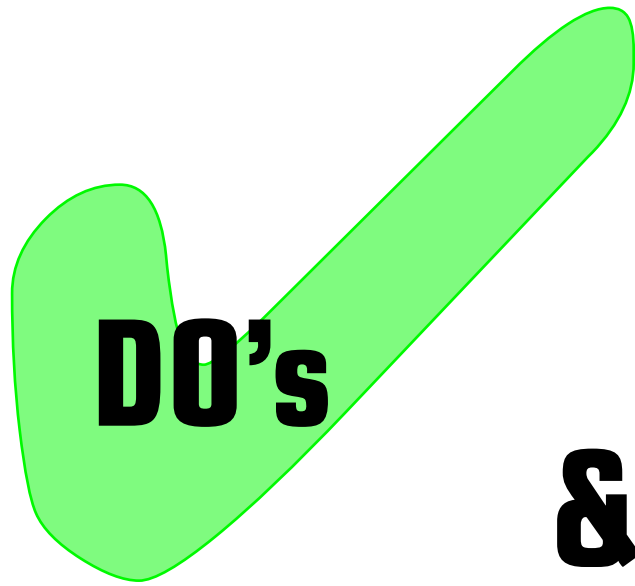

&



DIAGRAMS

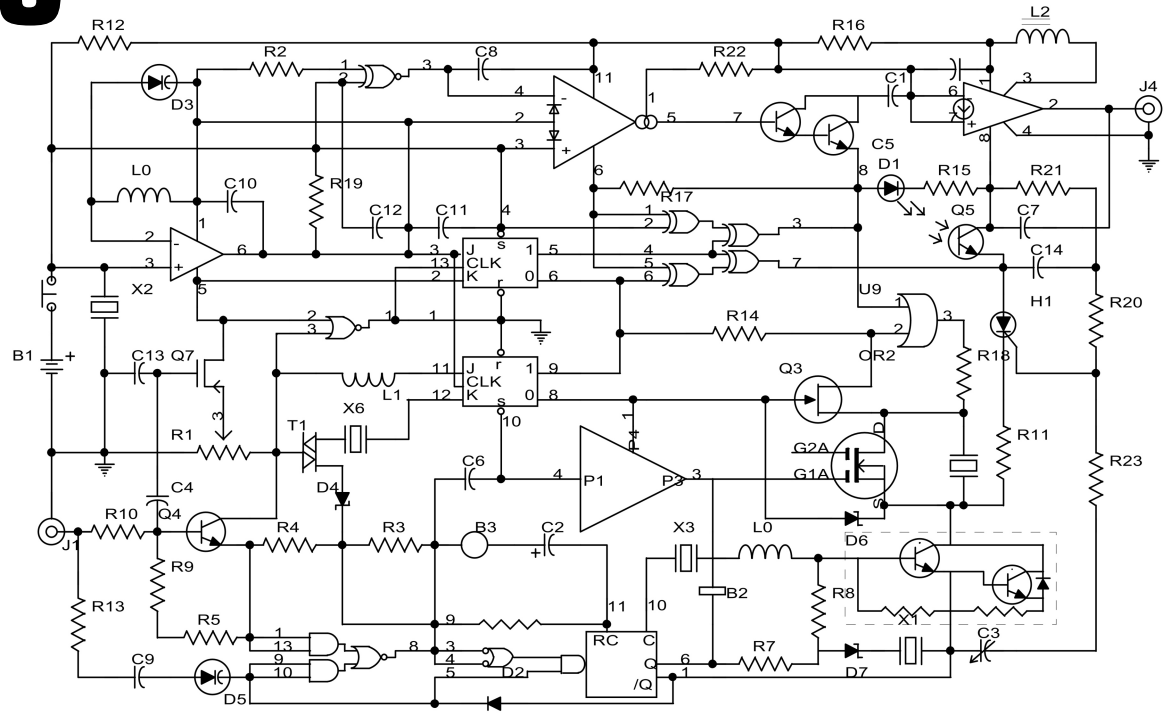

PROCESS



CHARTS & GRAPHS

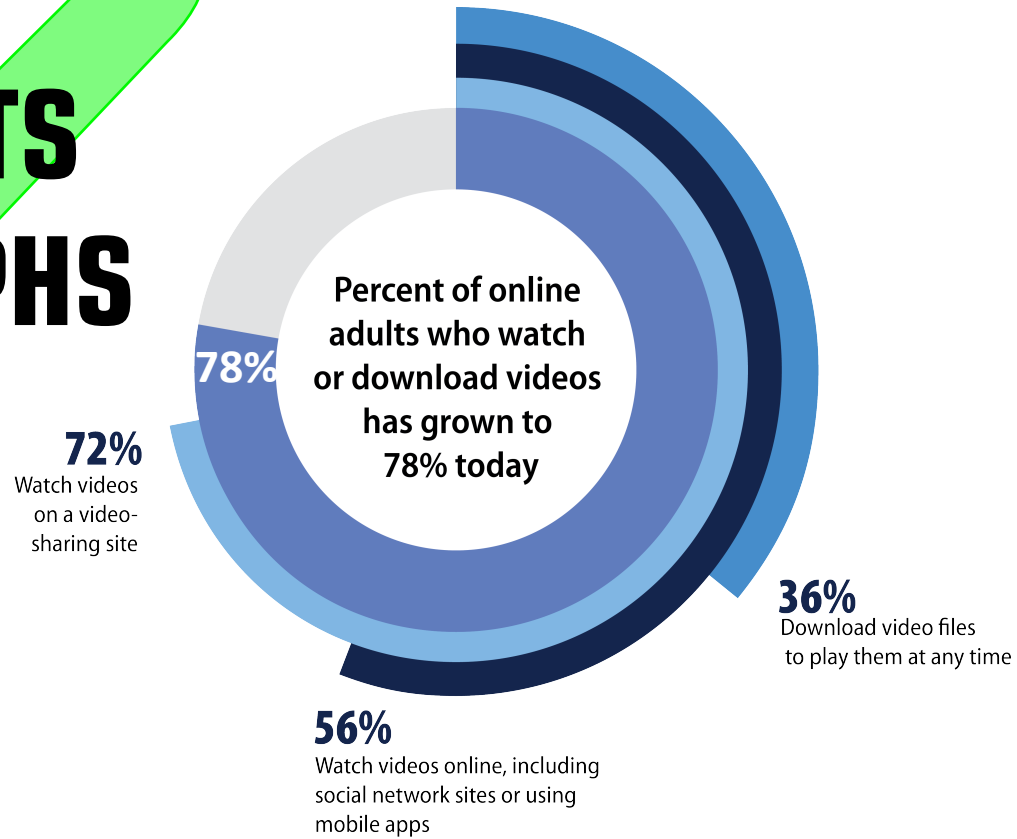

Source: pewInternet.org
(Online Video 2013)



**EVOKE
EMOTION**

TELEPROMPTER



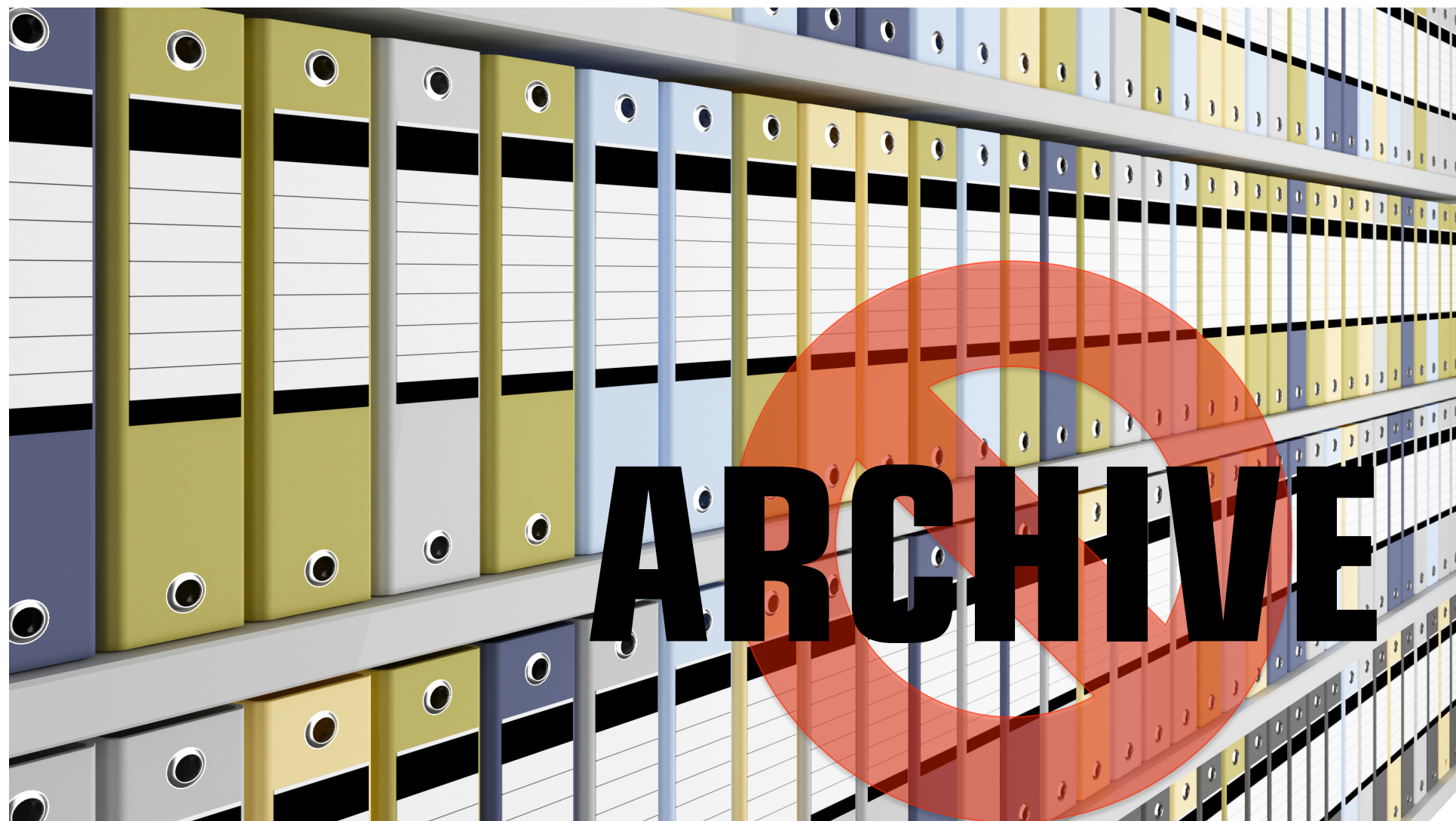

Too Much Text

Why Speakers Write Out Speeches on Slides

- Speaker assumes audience wants to read
- Presentation culture of organization dictates all major/minor points included
- Speaker uses slide as teleprompter
- Organization intends to use slide as archive document

Traci Nathans-Kelly & Christine G. Nocmeto

*Slide Rules: Design, Build & Archive Presentations
in the Engineering & Technical Fields (p.50)*



Cognitive Theory for Presentations

“Chunking” Information

2023473000

202	347	3000
2-0-2	347	3000

The magic number 7, +/- 2

Information Processing Theory

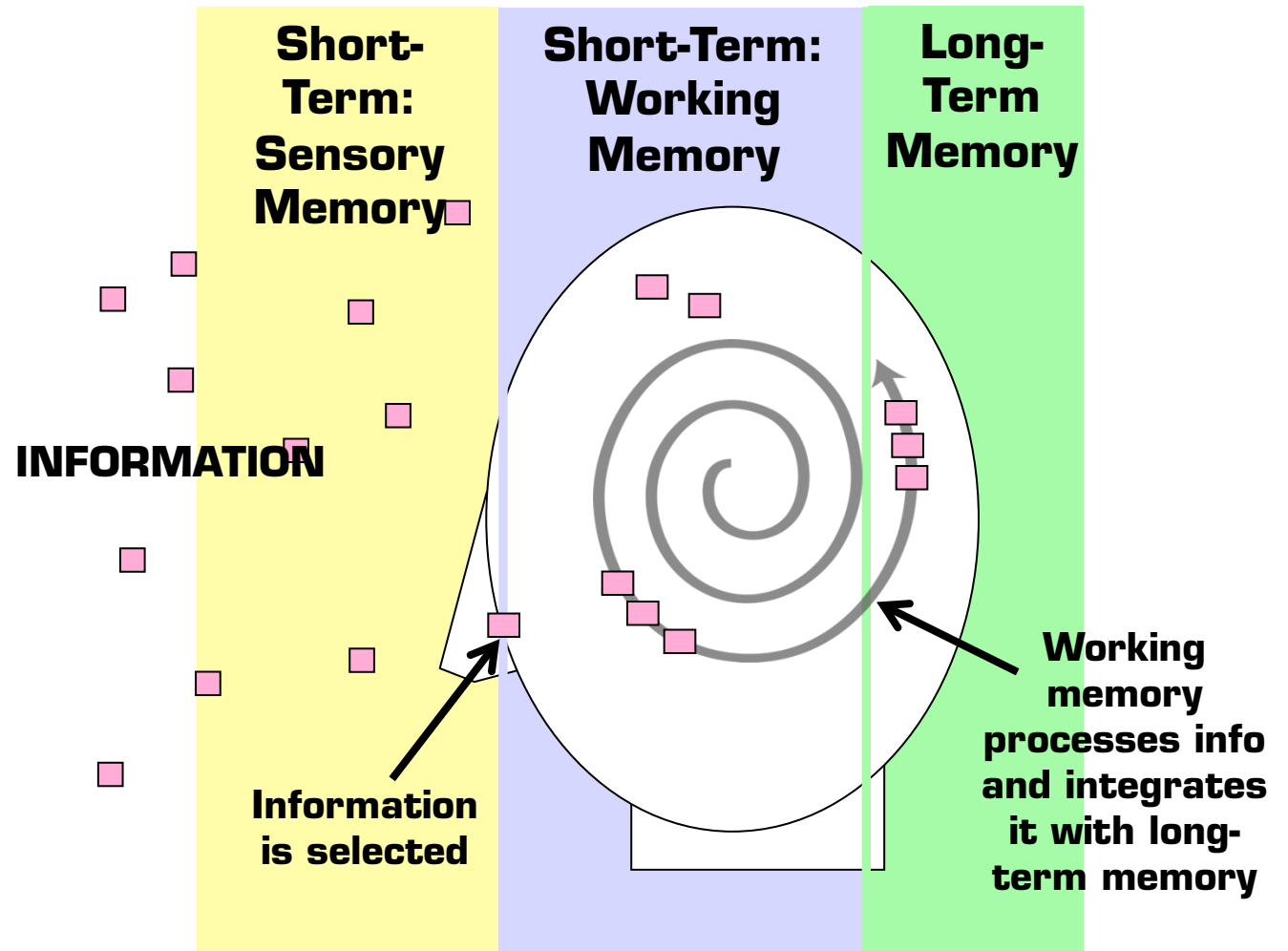

Based on illustration from Creating Graphics for Learning and Performance: Lessons in Visual Literacy (Lohr 34)

DUAL CODING THEORY

Verbal Memory



**Auditory/
Verbal
Channel**

Imaginal Memory



**Visual/
Pictorial
Channel**



Based on Pavio's Dual Coding theory (1990) from Creating Graphics for Learning and Performance: Lessons in Visual Literacy (Lohr 34)



**Auditory/
Verbal
Channel**



**Visual/
Pictorial
Channel**

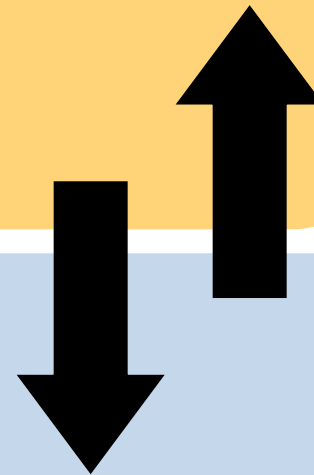

Based on Pavis's Dual Coding theory (1990) from Creating Graphics for Learning and Performance: Lessons in Visual Literacy (Lohr 34)

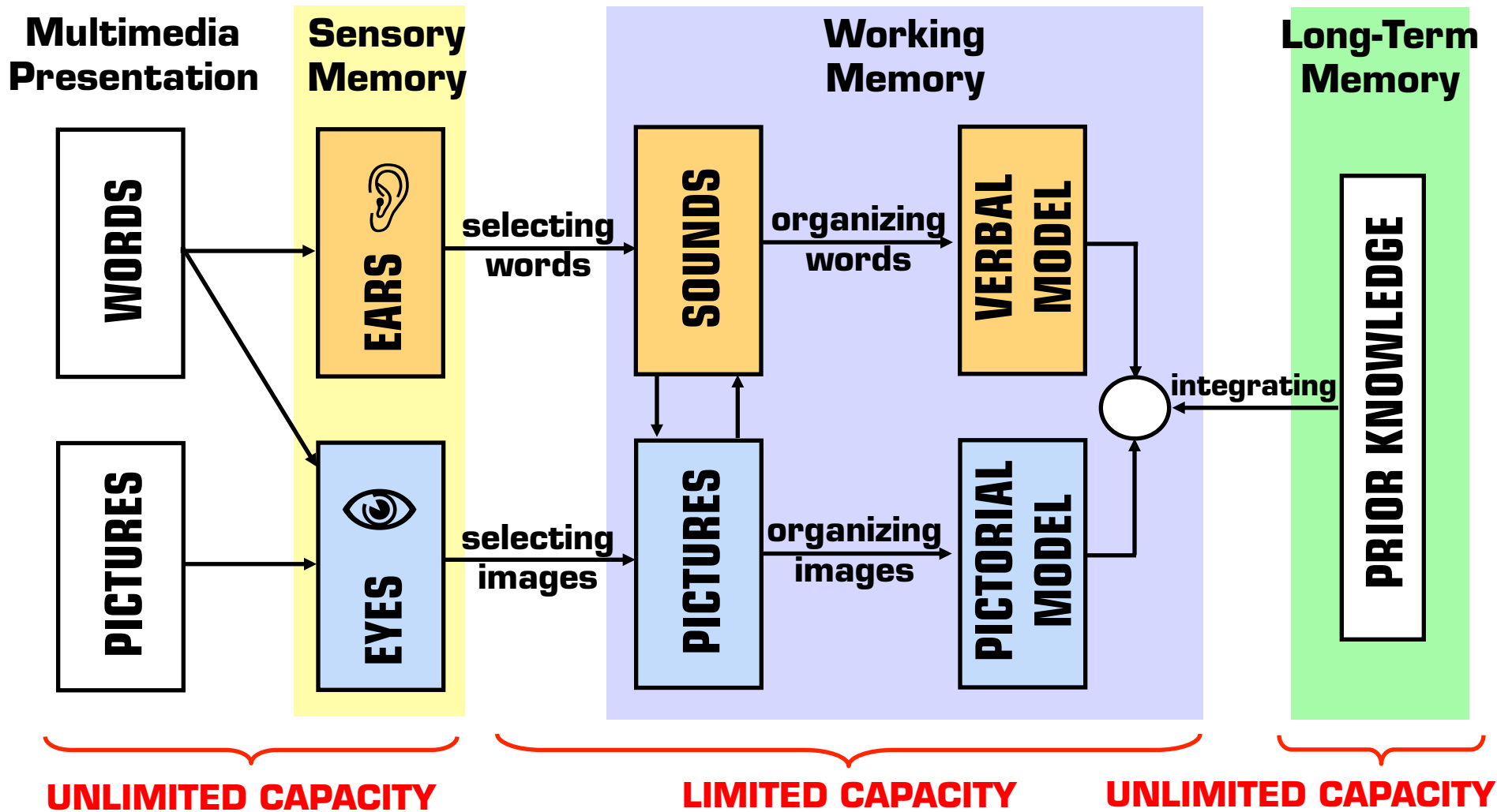

A Thought on Reading Slides

- Can you read this on the screen? Of course you can.
- You can also hear me reading these same words to you.
- But, you'll have more difficulty processing them and moving them into your memory because of cognitive overload.

Don't forget Mayer & Moreno's (2000) research



**Your presentation file may not
be your best handout document**

The image shows a woman in a light blue business shirt holding a clipboard. The clipboard displays a presentation slide with various data visualizations. At the top, there is a bar chart with a line graph overlaid. Below that, there is a pie chart and another bar chart. The text on the slide is partially obscured by the large yellow text overlay. The background is a blurred office setting with windows and lights.

“B” key = black screen
“W” key = white screen

Come to the Dark SLIDE

(Luke, I am your presentation designer!)



dark4.me



Questions?

Branded Templates or DIY?

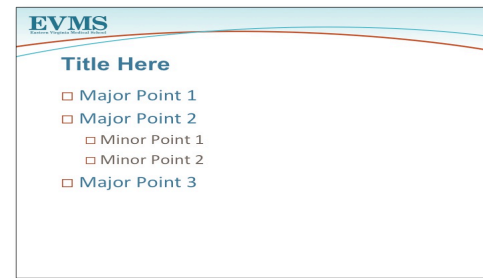

You might try creating your own templates

***PLEASE, avoid using
the stock templates in PowerPoint!***

Use the Slide Master

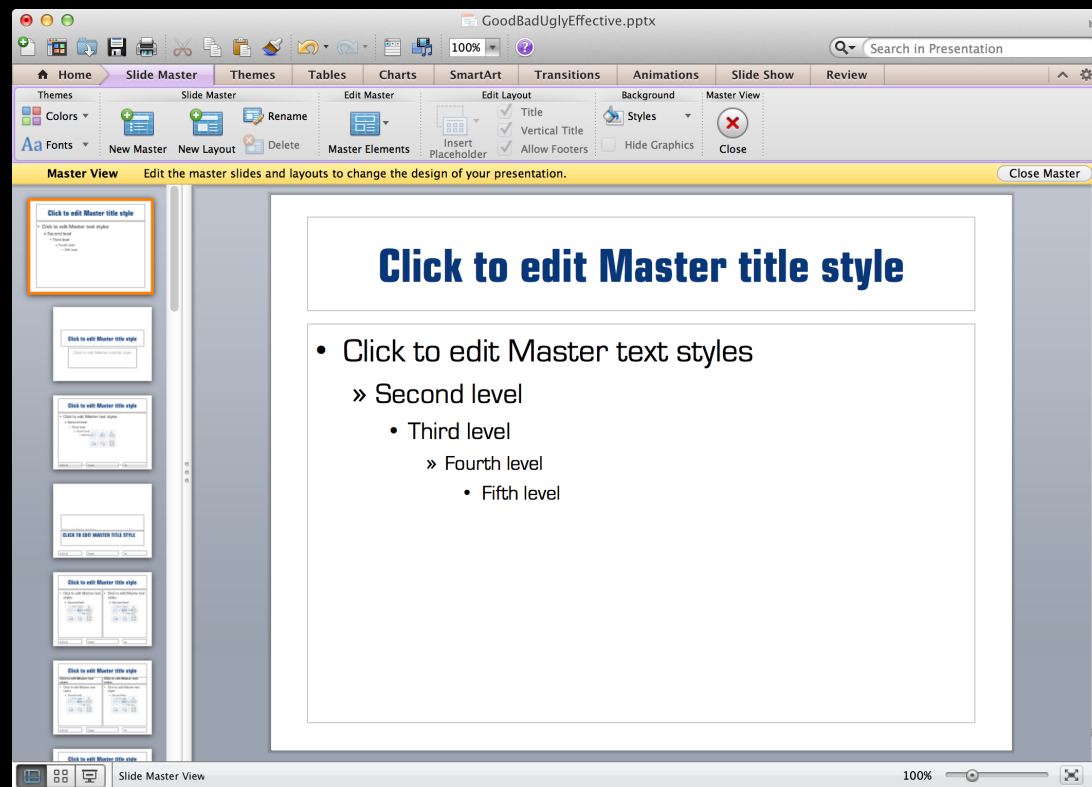

Checking for appropriate font size

- **Rarely should use any size less than 24 points**
- **In the venue:** Stand in the back of the room at your venue and view all slides
- **Guy Kawasaki's rule: Divide the oldest investor's age in half to get minimum font size**

Find a Strong Visual Metaphor



Example: Hitting Home Runs in Media Relations

On the receiving end
(reactive media relations)

- Calls from local, regional & national media
- Attempts to localize stories
- "Help A Reporter Out" (3x/day)



Pitching the Story
(proactive media relations)

- Regular pitches to media
- EurekAlert
- EVMS News Vehicles



Our Own News Vehicles

- EVMS Magazine
- Making the Rounds (e-newsletter)
- Web Site
- Speeches
- Donor Solicitations
- Coming Soon: Video & Social Media



EVMS
Proudly Supporting the Community
Pre-empting. Promoting. Growing.



How We Can Help with the Media

Hitting a Home Run



Helping the Team Win





Selecting Strong Images

Coping with Backgrounds



Format Picture >>

Recolor >>

Set Transparent
Color >>

CLICK ON COLOR
TO REMOVE

Image Coherence



Rule of Thirds Photo Example



Rule of Thirds Slide Example



Image Resources

Pay Sites

- **ThinkStock:**
www.thinkstock.com
- **Dreams Time:**
www.dreamstime.com
- **Fotolia:**
www.fotolia.com
- **Shutter Stock:**
www.shutterstock.com

Free Sites

- **Morgue File:**
www.morguefile.com
- **Flickr Creative Commons:**
[www.flickr.com/
creativecommons](http://www.flickr.com/creativecommons)
- **Everystockphoto:**
www.everystockphoto.com

Find a Visual Metaphor: Use these sites as search engines!

Consider Video



Determining the Right Visual

- Is the information included in the graphic suitable for purpose of the talk?
- Is the information included suitable for a graphic?
- What sort of graphic makes the most sense?

Traci Nathans-Kelly & Christine G. Nocmeto

*Slide Rules: Design, Build & Archive Presentations
in the Engineering & Technical Fields (p. 111)*

EVMS

R01-Equivalent grants Applications, awards, and success rates

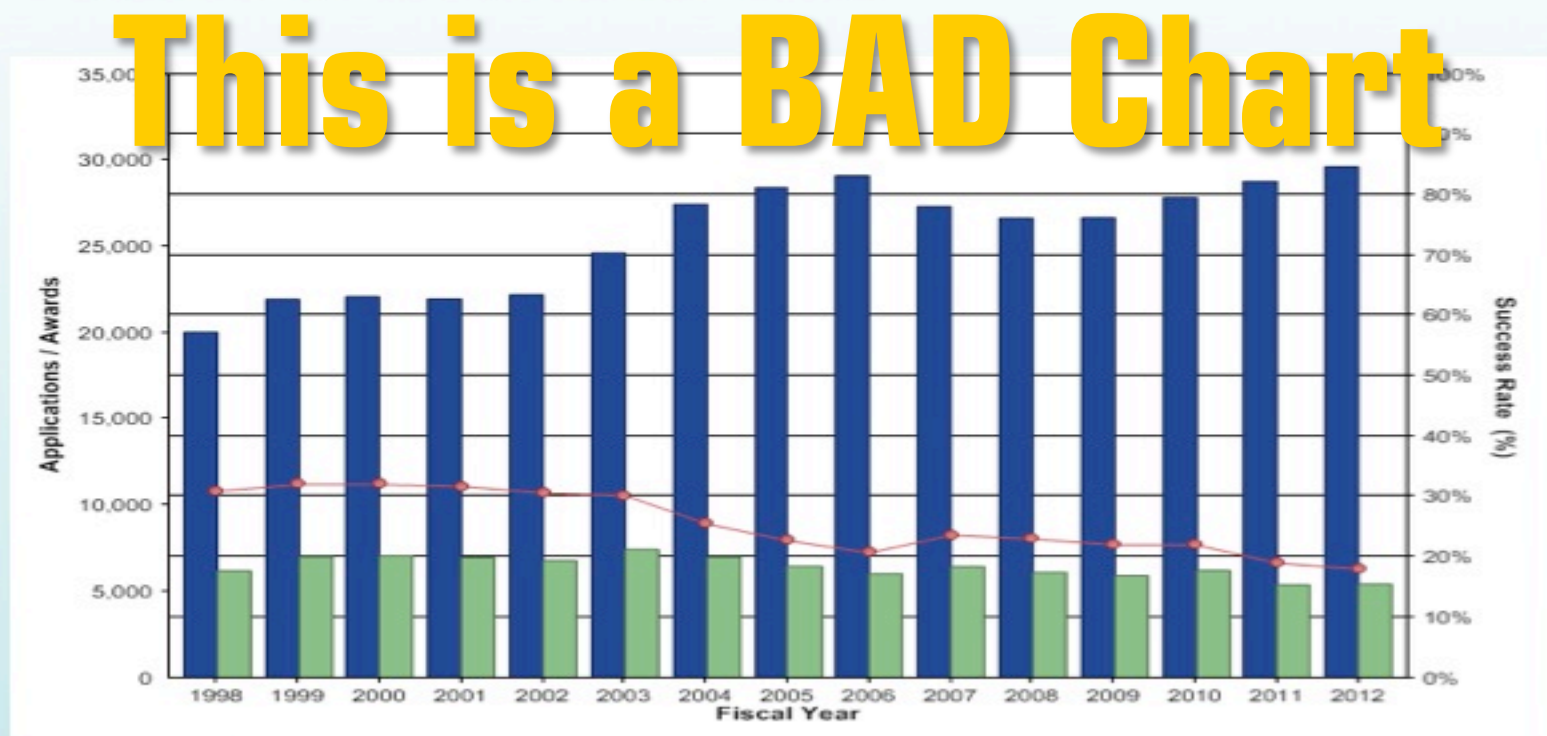

Source - NIH

Do you need a chart, graph or table?

73.4 %
of speechwriters
fantasize about
killing their speakers
during the writing &
rehearsing process



Picture Superiority Effect

Memory retention after 3 days

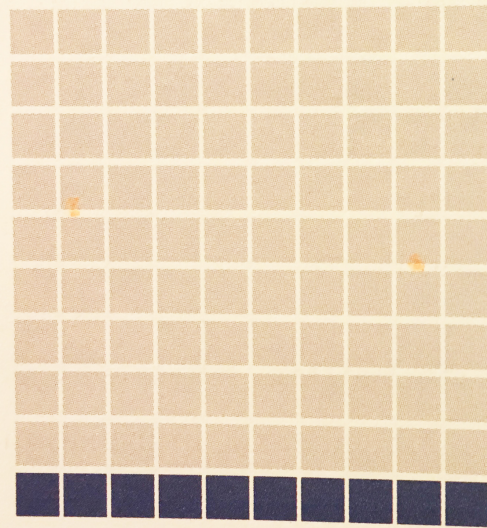

10%
Text or Audio Only

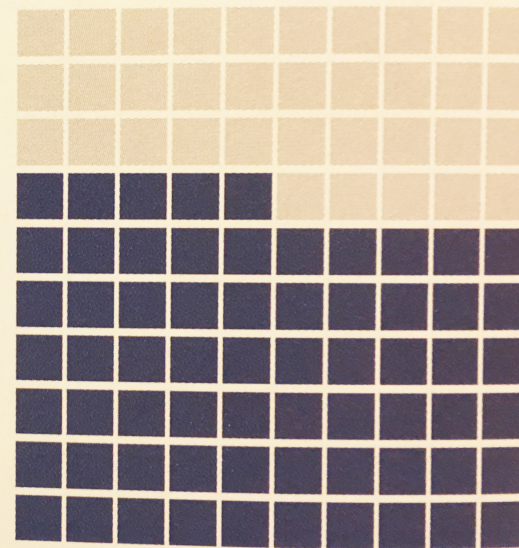

65%
Text + Picture

Simplify, Simply, Simplify!

800%
increase in number
of online videos
watched in just
6 years

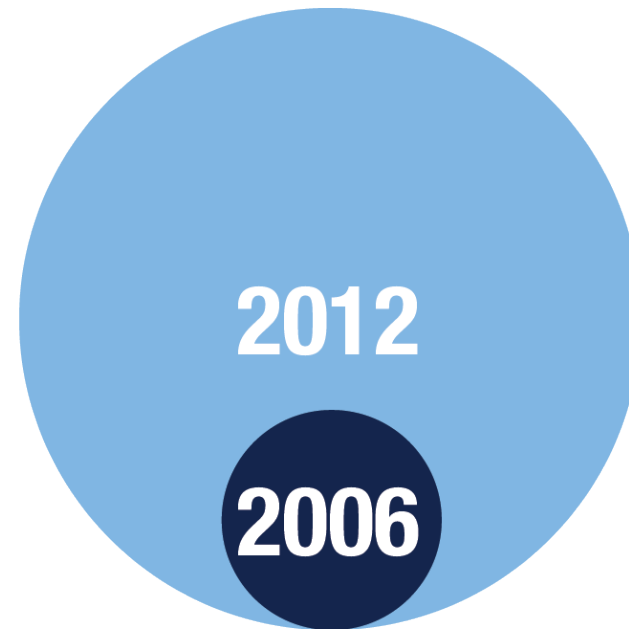

Source: comScore Video Metrix, December 2012

Simplify, Simply, Simplify!

2012 Store Openings

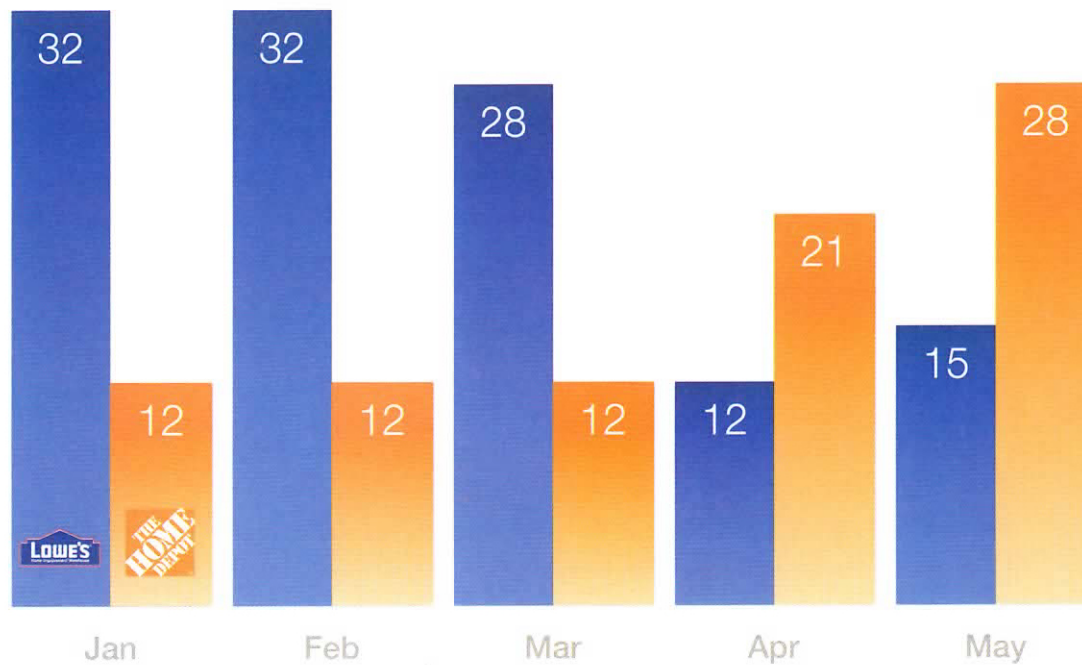

Simplify, Simply, Simplify!

Performance overview

■ Our business

- Competitor A
- Competitor B
- Competitor C
- Competitor D
- Competitor E



Limit Colors (Use for emphasis)

New Marriage Rate by Education

Number of newly married adults per 1,000 marriage eligible adults

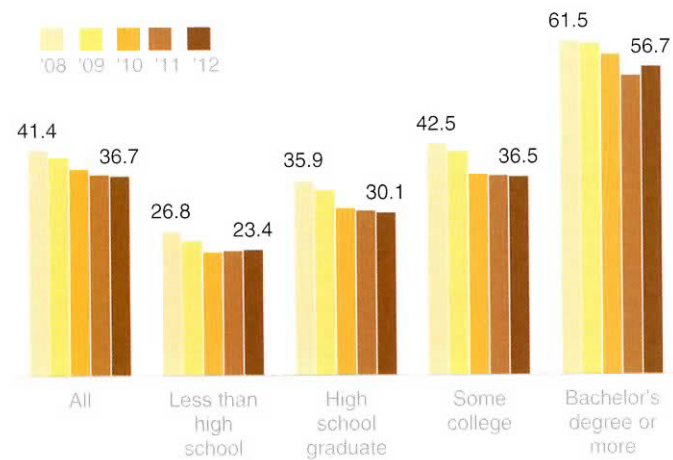

Note: Marriage eligible includes the newly married plus those widowed, divorced, or never married at interview.

Source: U.S. Census

Adapted from PEW RESEARCH CENTER

New Marriage Rate by Education

Number of newly married adults per 1,000 marriage eligible adults

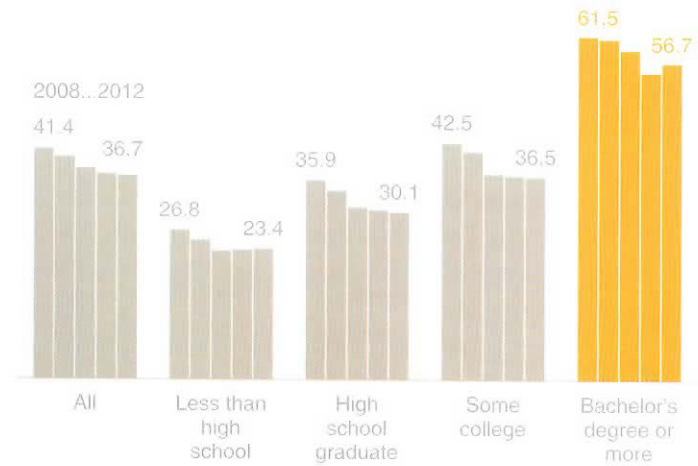

Note: Marriage eligible includes the newly married plus those widowed, divorced, or never married at interview.

Source: U.S. Census

Adapted from PEW RESEARCH CENTER

Know What You Want to **HIGHLIGHT**



EVMS

R01-Equivalent grants Applications, awards, and success rates

Applications Awards Success Rate (%)

Avoid Template Crowding

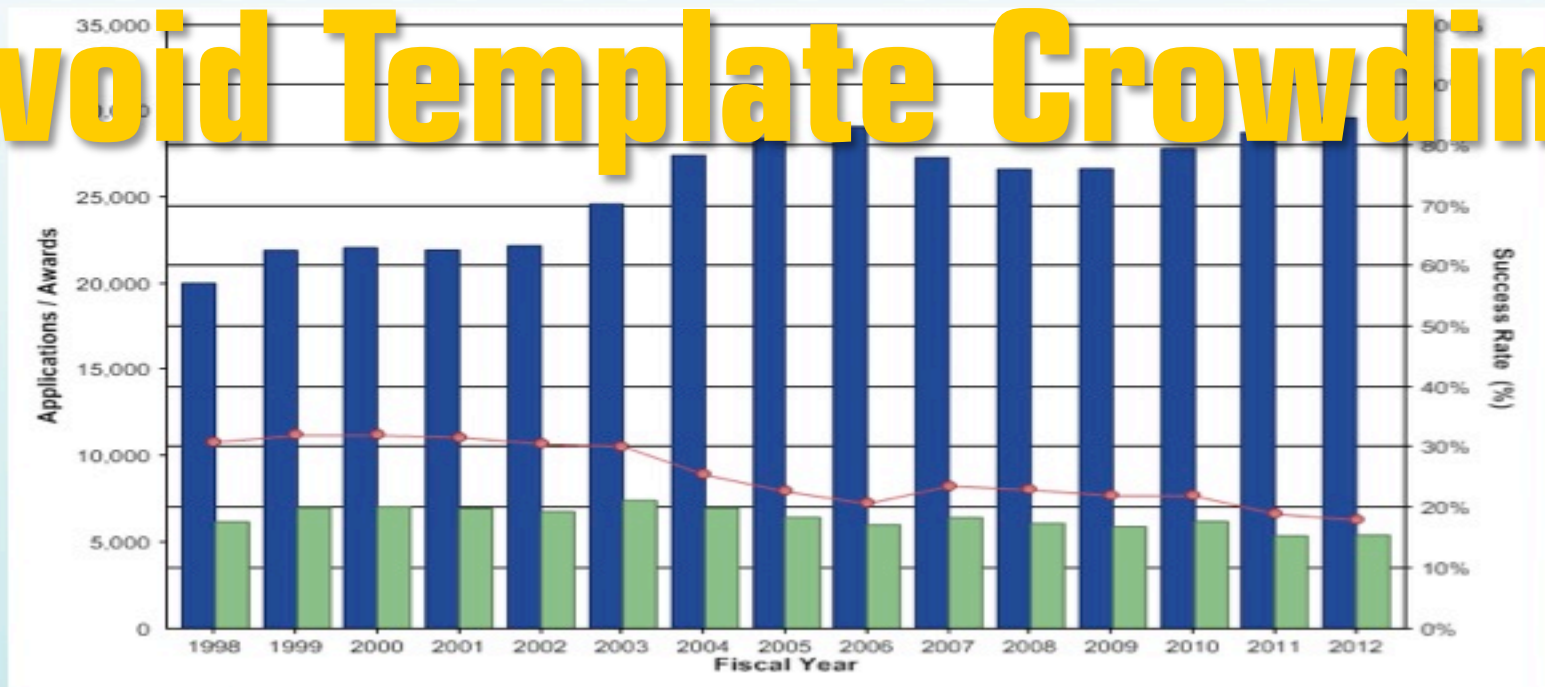

Source - NIH

EVMS Template Example

Avoid 3D Distortions

Sales

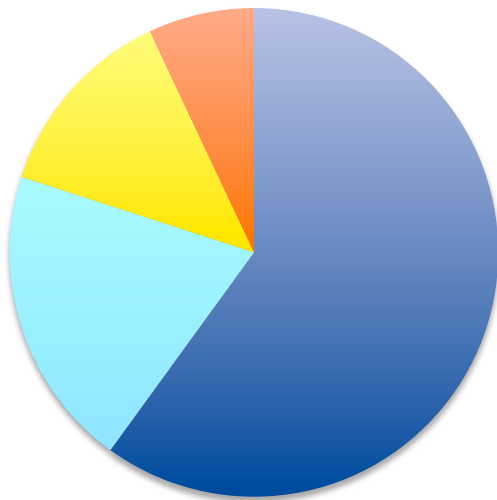

- Product A
- Product B
- Product C
- Product D

Sales

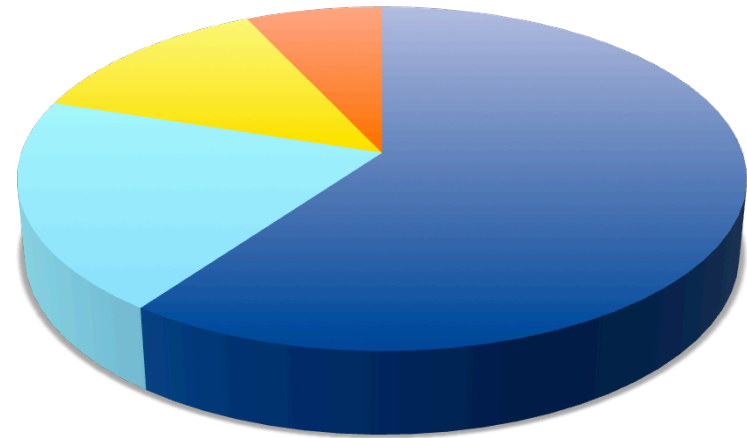

Present Data in Clearest Way Possible

- Tell the truth
- Get to the point
- Pick the right tool for the job
- Highlight what's important
- Keep it simple

Nancy Duarte

slide:ology (p. 65)

Managing Motion



Text Animations

- For the love of all the presentation gods, PLEASE don't use crazy text animations just because you can. It's distracting... and, often, **annoying**.
- I mean it. PLEASE don't do it.
- Pretty please?

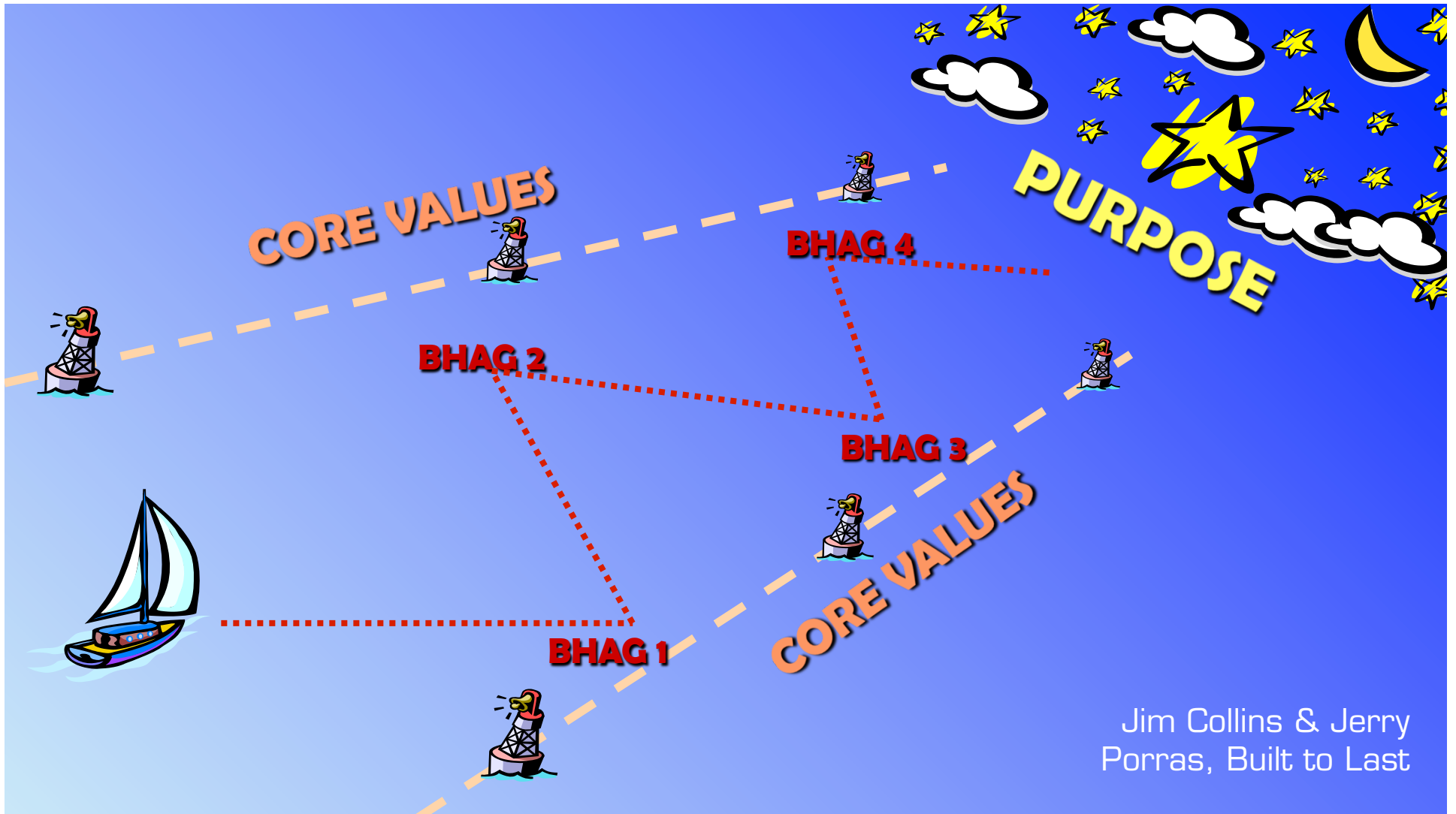

Jim Collins & Jerry Porras, Built to Last

**Norfolk Public
Schools
“A” Frame
For Continuous
Improvement**

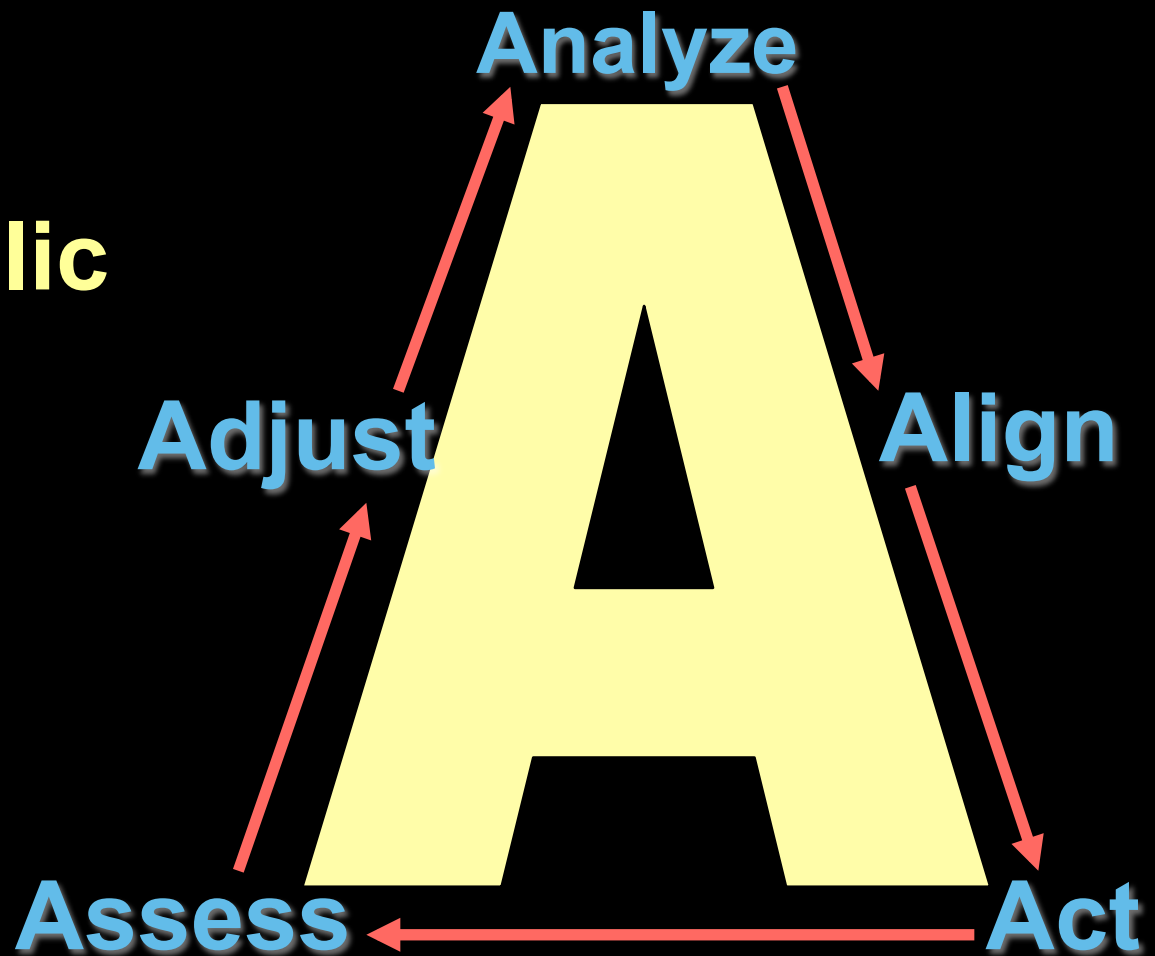

Think beyond the single slide

Expand your canvas via transitions & animations



animation



shortened path

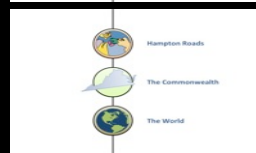

shortened path



animation



animation

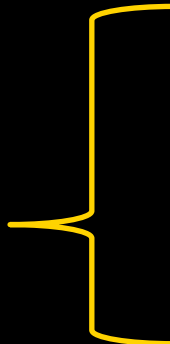
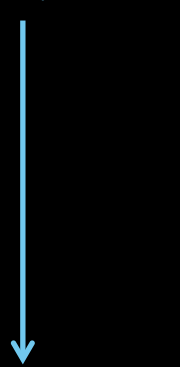
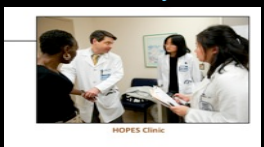
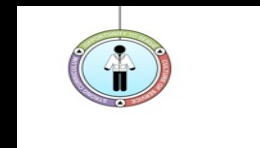
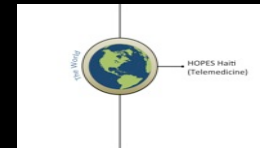
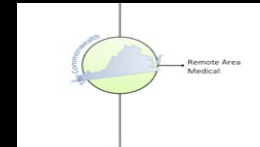
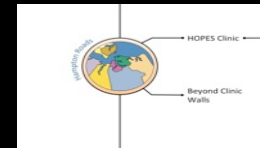
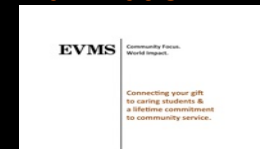

An Alternative to Slides



www.prezi.com



Questions

Vincent Rhodes, PhD, APR
varhodes@gmail.com
@varhodes



Good



Bad



Ugly



Effective



Getting the Most Out of Presentation Software

Vincent Rhodes, PhD, APR
varhodes@gmail.com
@varhodes



An Alternative Presentation Style

O'REILLY
OPENSOURCE
CONVENTION

Keynote
Identity 2.0

Dick Hardt

Founder and CEO | Sxip Identity