

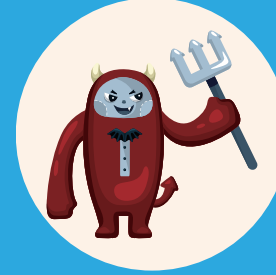



<i>Good</i>	<i>Bad</i>	<i>Ugly</i>	<i>Effective</i>
			
<p><i>Getting the Most Out of Presentation Software</i></p>			
<p>Vincent Rhodes, PhD, APR varhodes@gmail.com @varhodes</p>			

WARNING:
THIS IS NOT A TYPICAL
PRESENTATION!

Is PowerPoint Evil ?



IS POWERPOINT A TOOL?

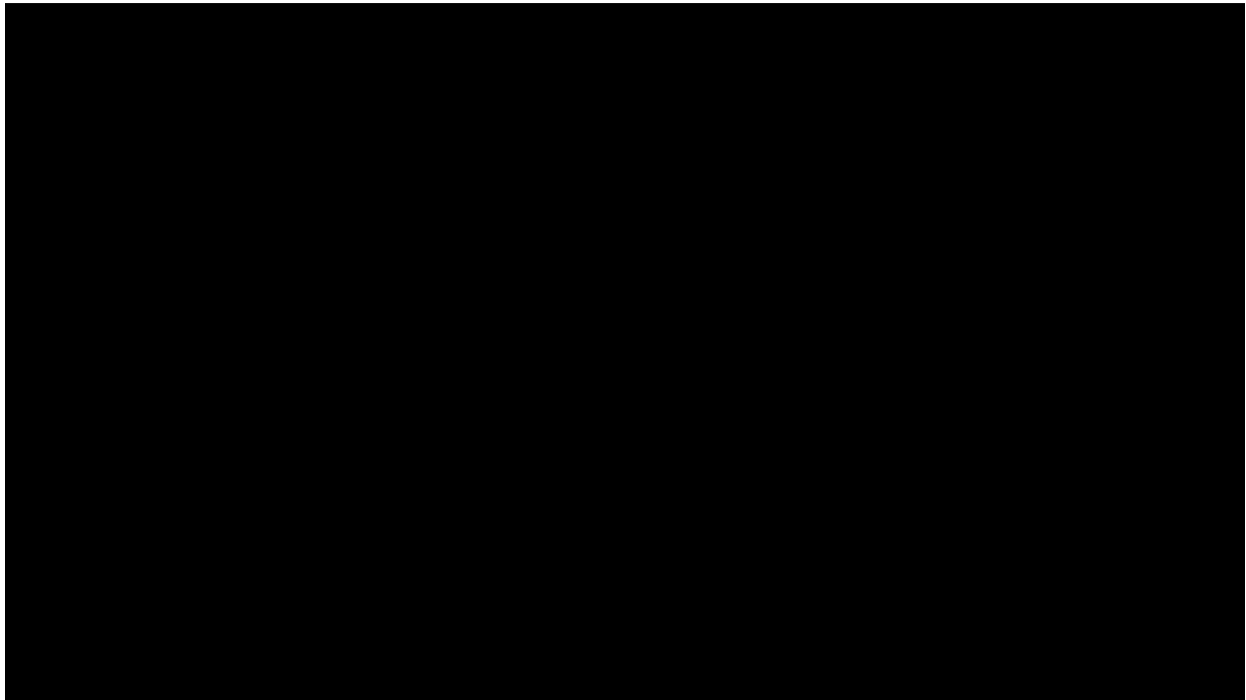







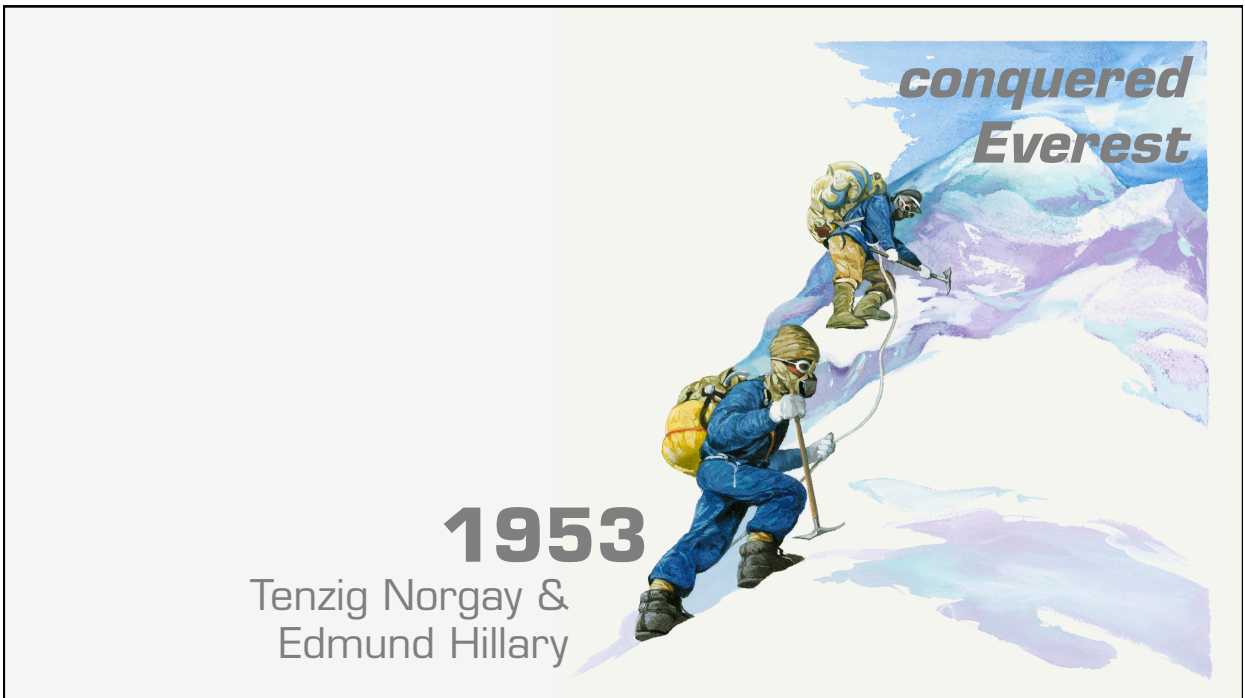





What Makes Messages Stick?

Unexpectedness

Concreteness

Simplicity

Garr Reynolds, *Presentation Zen* (p. 77)

Always Write the Speech First. Usually.

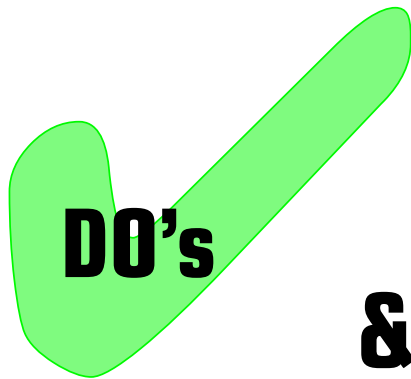

&



DIAGRAMS

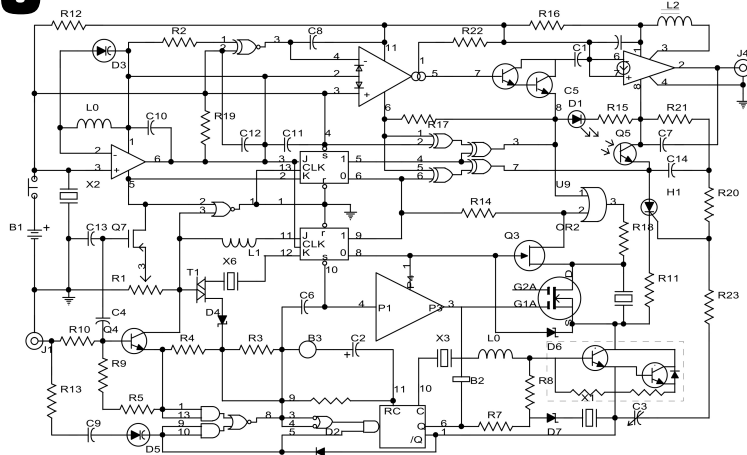

PROCESS



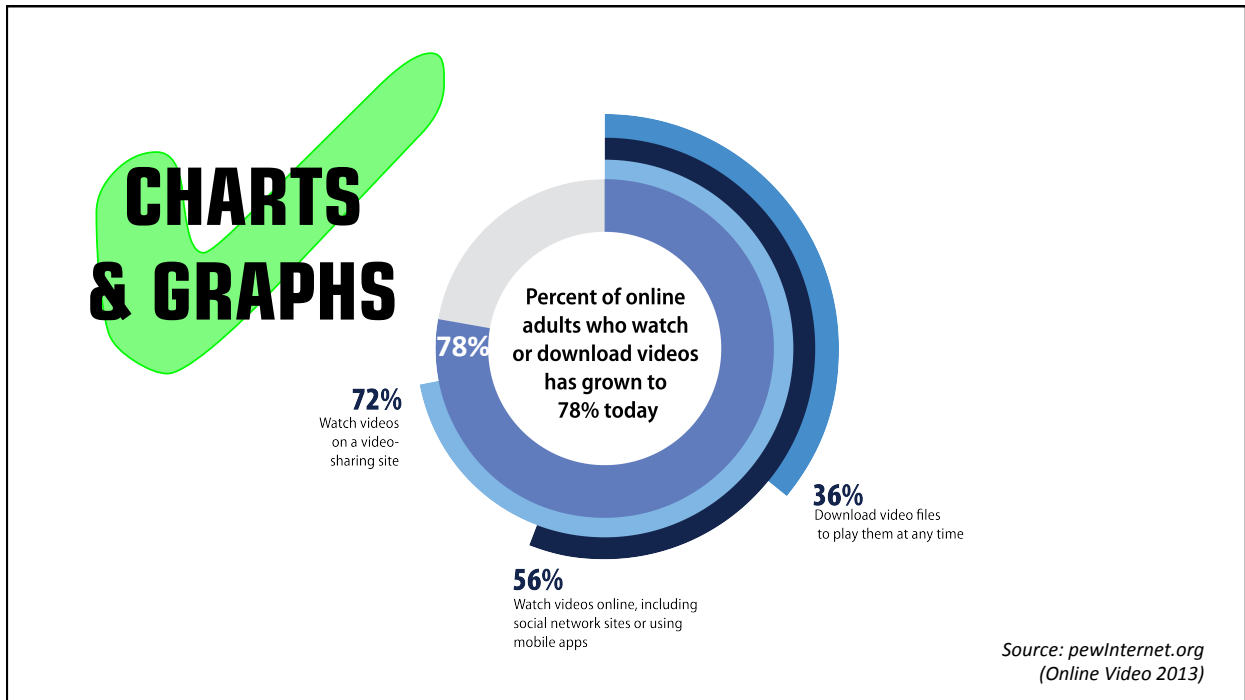

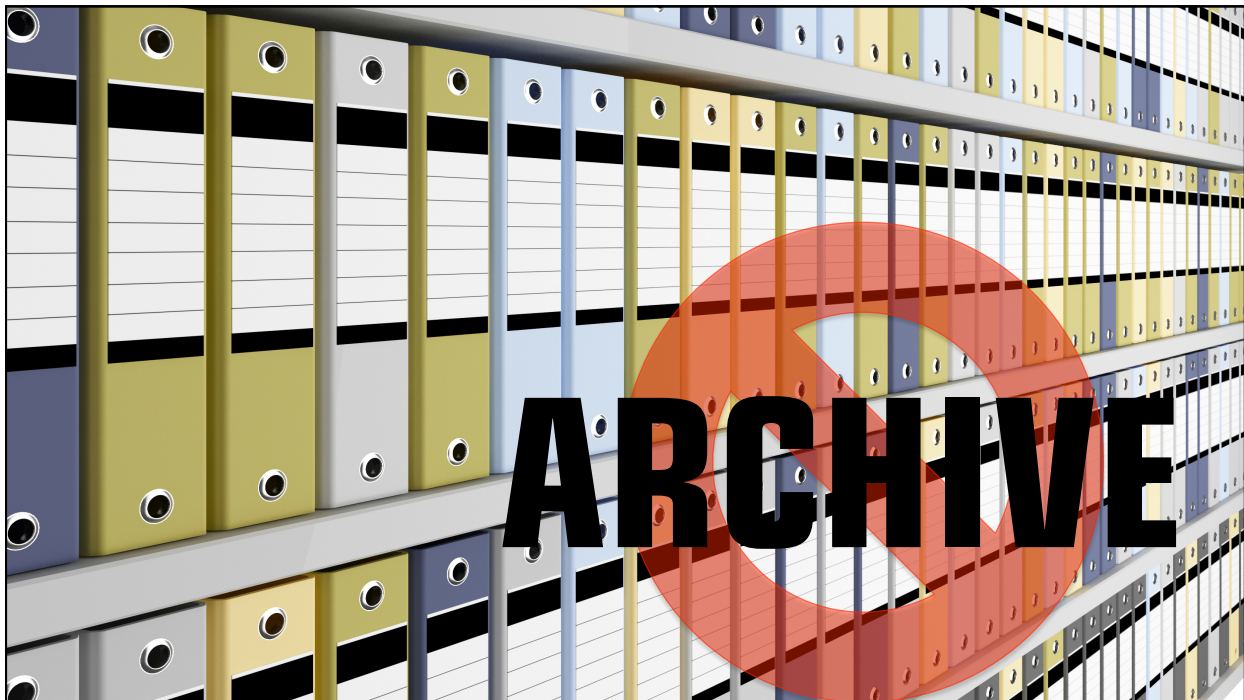

Too Much Text

Why Speakers Write Out Speeches on Slides

- Speaker assumes audience wants to read
- Presentation culture of organization dictates all major/minor points included
- Speaker uses slide as teleprompter
- Organization intends to use slide as archive document

Traci Nathans-Kelly & Christine G. Nocmeto

*Slide Rules: Design, Build & Archive Presentations
in the Engineering & Technical Fields (p.50)*

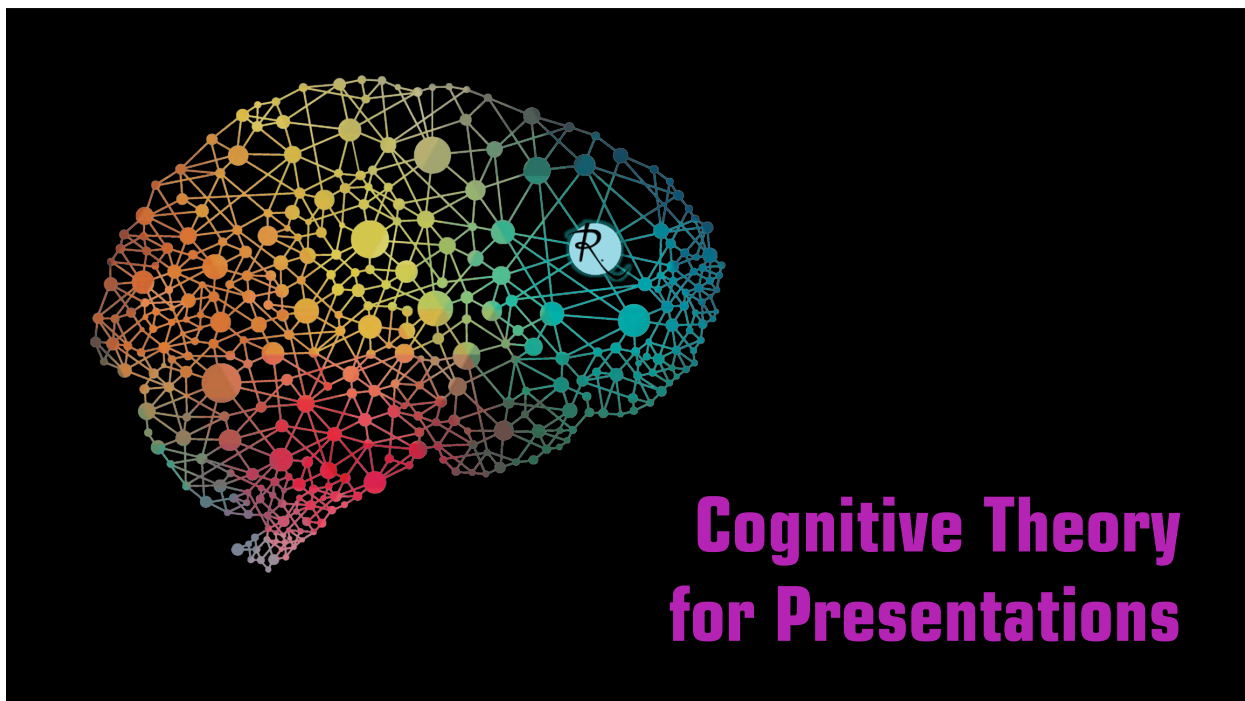

“Chunking” Information

2023473000

202 347 3000
2-0-2 347 3000

The magic number 7, +/- 2

Information Processing Theory

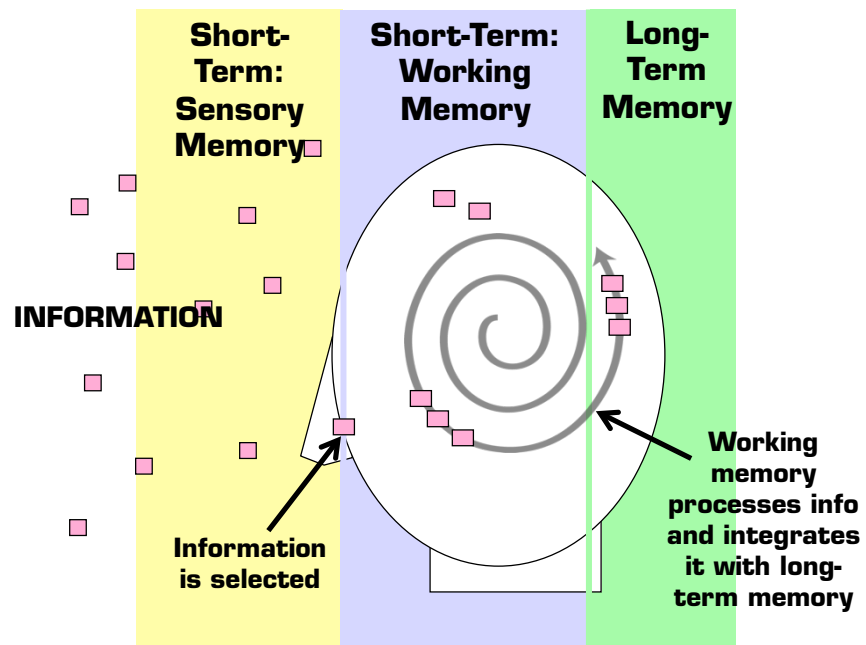

Based on illustration from Creating Graphics for Learning and Performance: Lessons in Visual Literacy (Lohr 34)

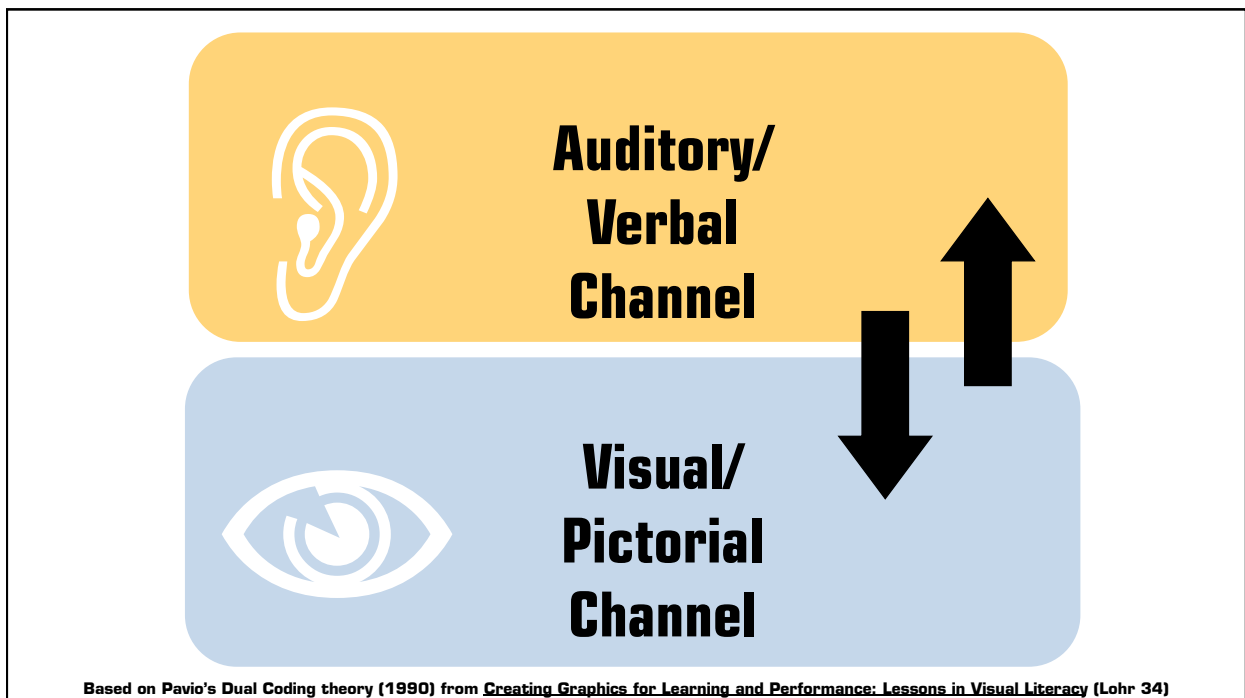
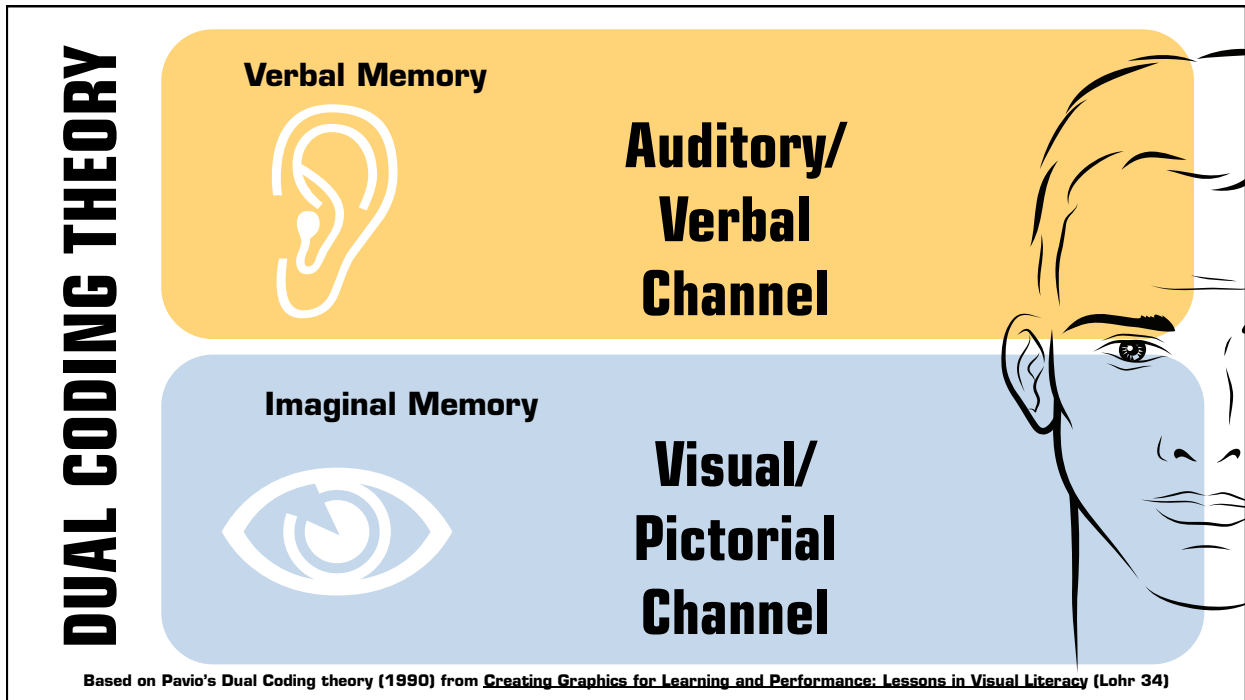

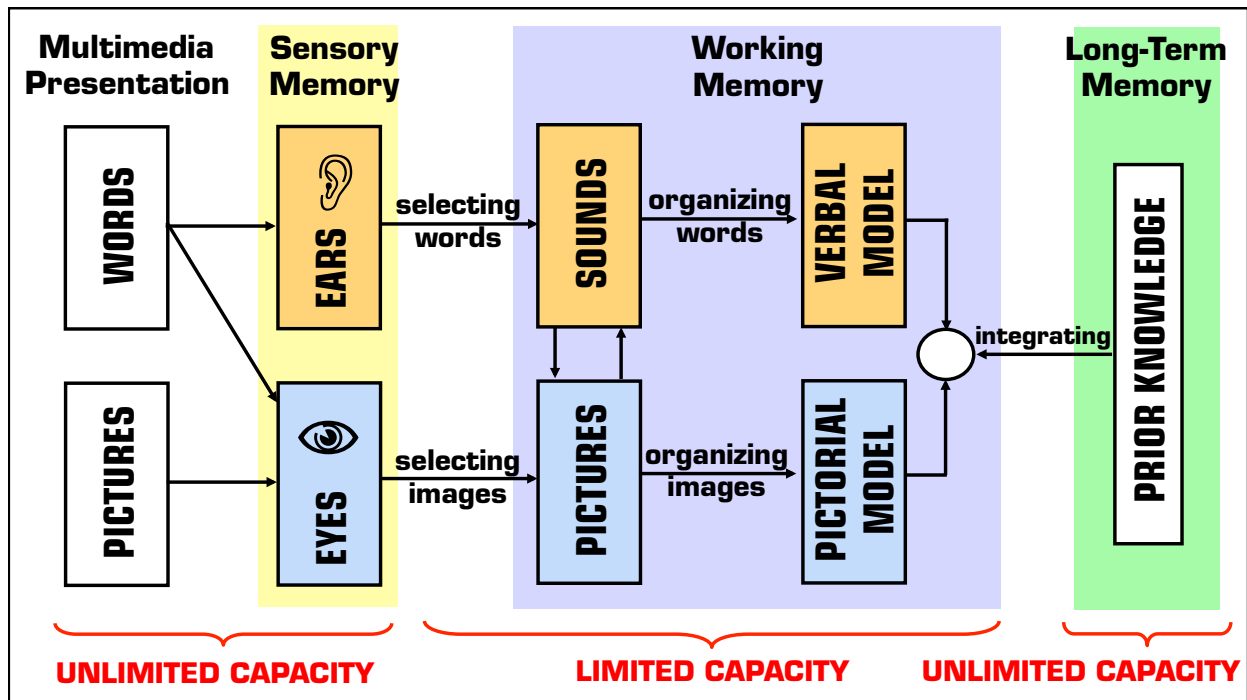

A Thought on Reading Slides

- Can you read this on the screen? Of course you can.
- You can also hear me reading these same words to you.
- But, you'll have more difficulty processing them and moving them into your memory because of cognitive overload.

Don't forget Mayer & Moreno's (2000) research

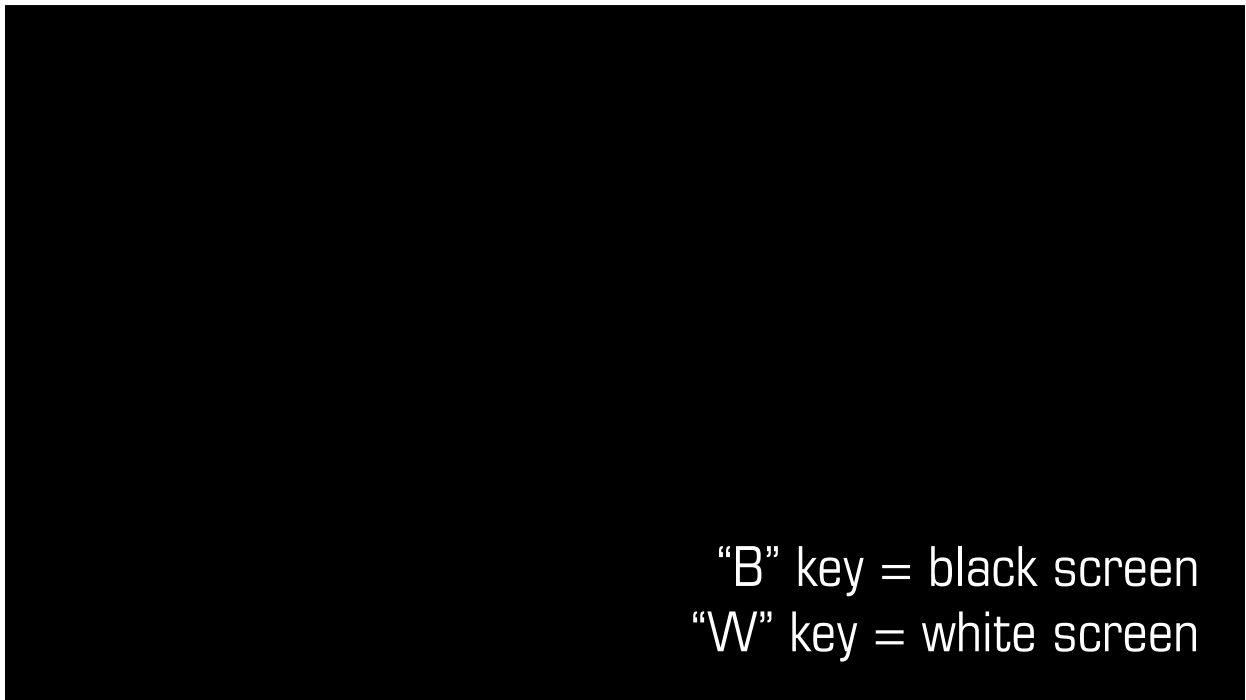



Branded Templates or DIY?

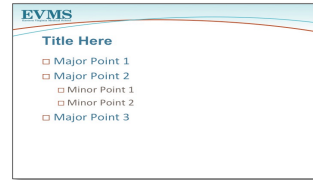

You might try creating your own templates

***PLEASE, avoid using
the stock templates in PowerPoint!***

Use the Slide Master

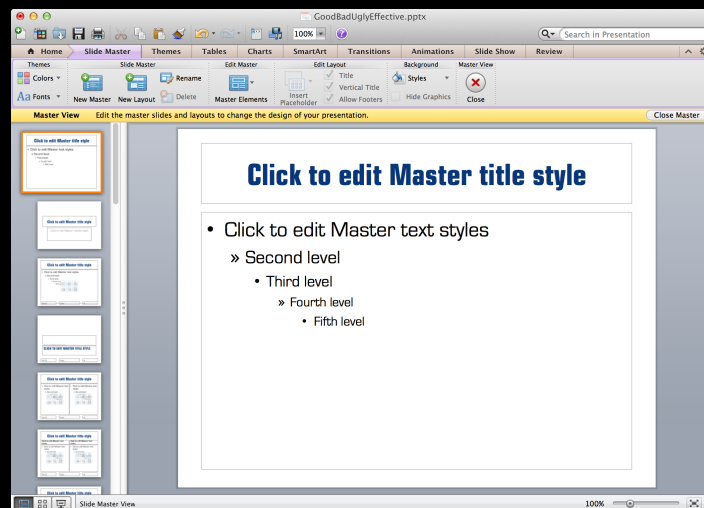

Checking for appropriate font size

- **Rarely should use any size less than 24 points**
- **In the venue:** Stand in the back of the room at your venue and view all slides
- **Guy Kawasaki's rule: Divide the oldest investor's age in half to get minimum font size**

Find a Strong Visual Metaphor



Example: Hitting Home Runs in Media Relations

On the receiving end
(reactive media relations)

Calls from local, regional & national media
Attempts to localize stories
"Help A Reporter Out" (3x/day)



Pitching the Story
(proactive media relations)

- Regular pitches to media
- EurekAlert
- EVMS News Vehicles



Our Own News Vehicles

- EVMS Magazine
- Making the Rounds (e-newsletter)
- Web Site
- Speeches
- Donor Solicitations
- Coming Soon: Video & Social Media



How We Can Help with the Media

Hitting a Home Run



Helping the Team Win



Coping with Backgrounds



Format Picture >>

Recolor >>

Set Transparent
Color >>

CLICK ON COLOR
TO REMOVE

Image Coherence



Rule of Thirds Photo Example



Rule of Thirds Slide Example



Image Resources

Pay Sites

- **ThinkStock:**
www.thinkstock.com
- **Dreams Time:**
www.dreamstime.com
- **Fotolia:**
www.fotolia.com
- **Shutter Stock:**
www.shutterstock.com

Free Sites

- **Morgue File:**
www.morguefile.com
- **Flickr Creative Commons:**
www.flickr.com/creativecommons
- **Everystockphoto:**
www.everystockphoto.com

Find a Visual Metaphor: Use these sites as search engines!

Consider Video



Determining the Right Visual

- Is the information included in the graphic suitable for purpose of the talk?
- Is the information included suitable for a graphic?
- What sort of graphic makes the most sense?

Traci Nathans-Kelly & Christine G. Nocmeto

*Slide Rules: Design, Build & Archive Presentations
in the Engineering & Technical Fields (p.111)*

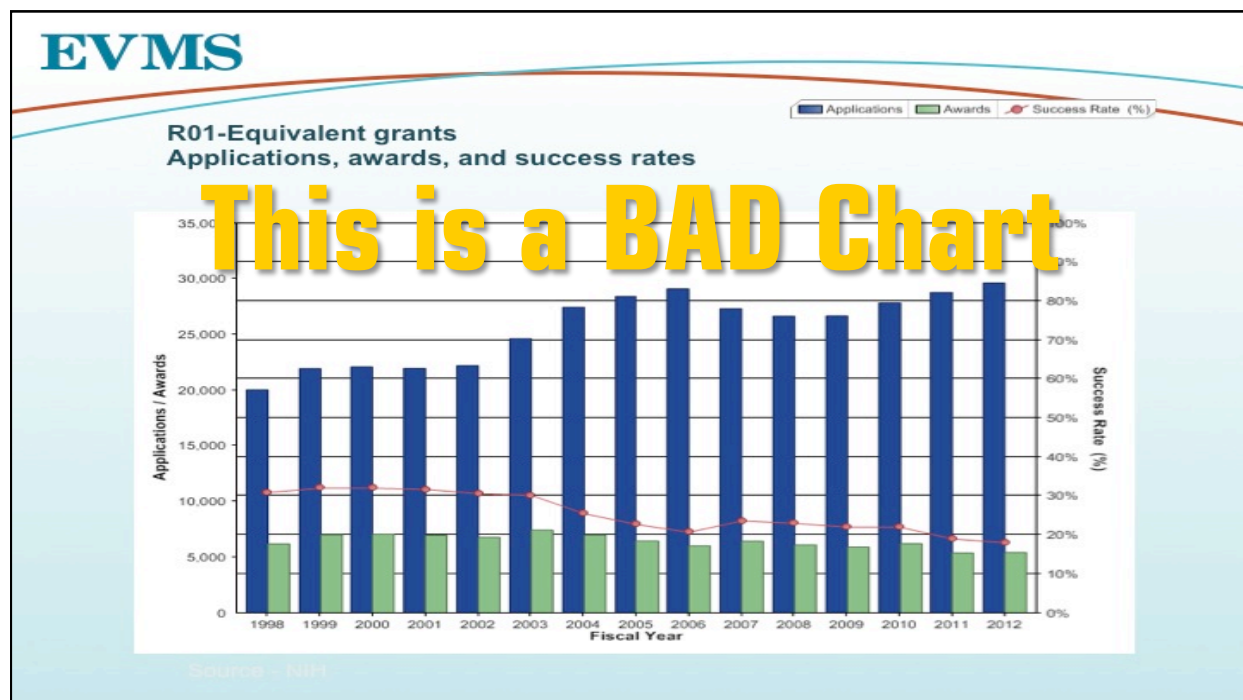

Do you need a chart, graph or table?

73.4 %
of speechwriters
fantasize about
killing their speakers
during the writing &
rehearsing process



Picture Superiority Effect

Memory retention after 3 days



10%
Text or Audio Only

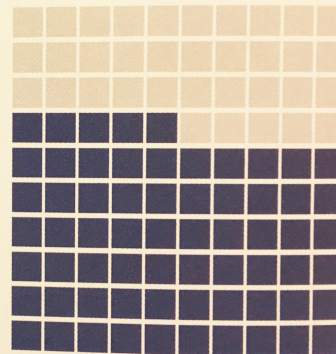

65%
Text + Picture

Simplify, Simply, Simplify!

800%
increase in number
of online videos
watched in just
6 years

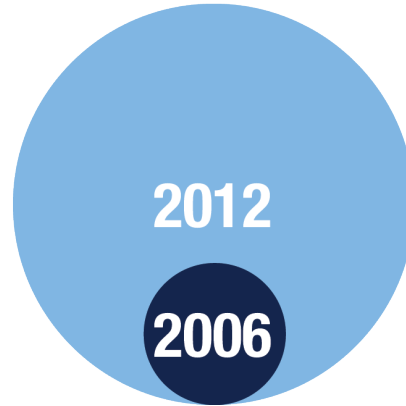

Source: comScore Video Metrix, December 2012

Simplify, Simply, Simplify!

2012 Store Openings

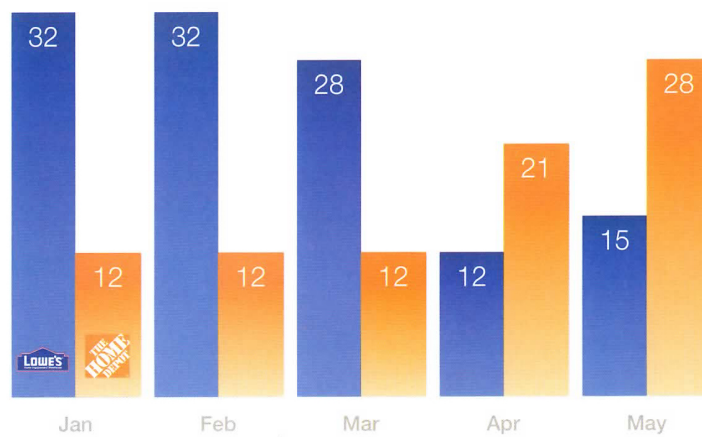

Simplify, Simply, Simplify!

Performance overview

■ Our business

- Competitor A
- Competitor B
- Competitor C
- Competitor D
- Competitor E



Limit Colors (Use for emphasis)

New Marriage Rate by Education

Number of newly married adults per 1,000 marriage eligible adults

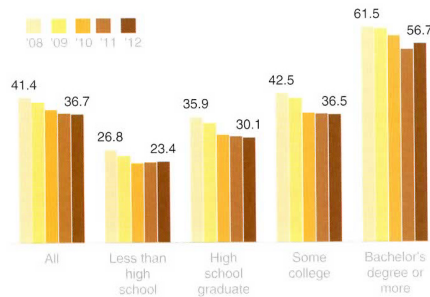

Note: Marriage eligible includes the newly married plus those widowed, divorced, or never married at interview.
 Source: U.S. Census
 Adapted from PEW RESEARCH CENTER

New Marriage Rate by Education

Number of newly married adults per 1,000 marriage eligible adults

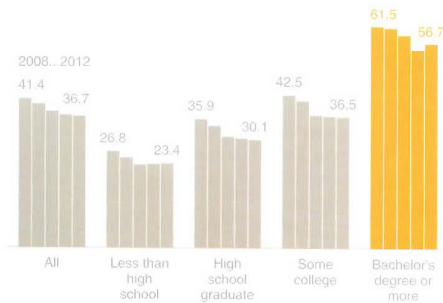

Note: Marriage eligible includes the newly married plus those widowed, divorced, or never married at interview.
 Source: U.S. Census
 Adapted from PEW RESEARCH CENTER

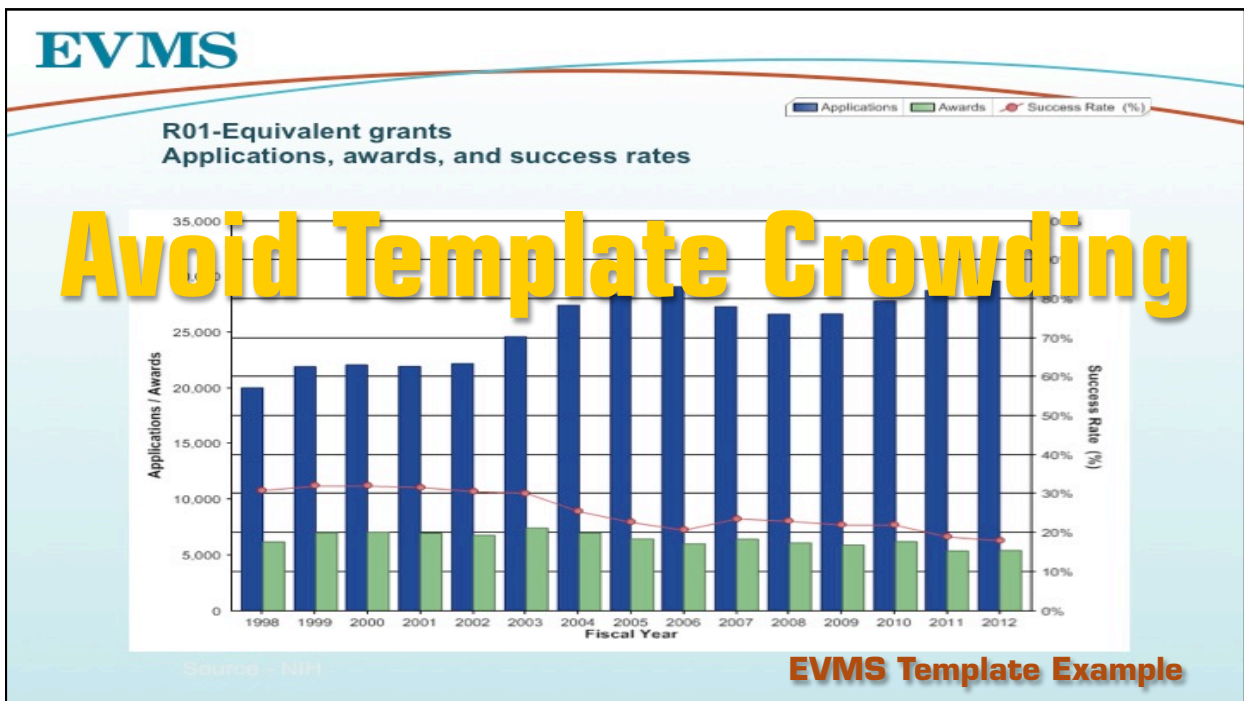

Avoid 3D Distortions

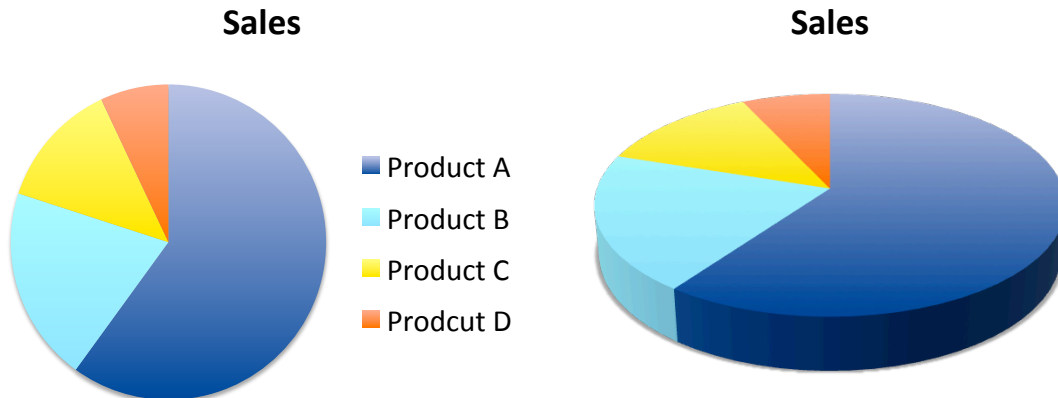

Present Data in Clearest Way Possible

- Tell the truth
- Get to the point
- Pick the right tool for the job
- Highlight what's important
- Keep it simple

Nancy Duarte
slide:ology (p. 65)



Text Animations

- For the love of all the presentation gods, PLEASE don't use crazy text animations just because you can. It's distracting... and, often, **annoying**.
- I mean it. PLEASE don't do it.
- Pretty please?

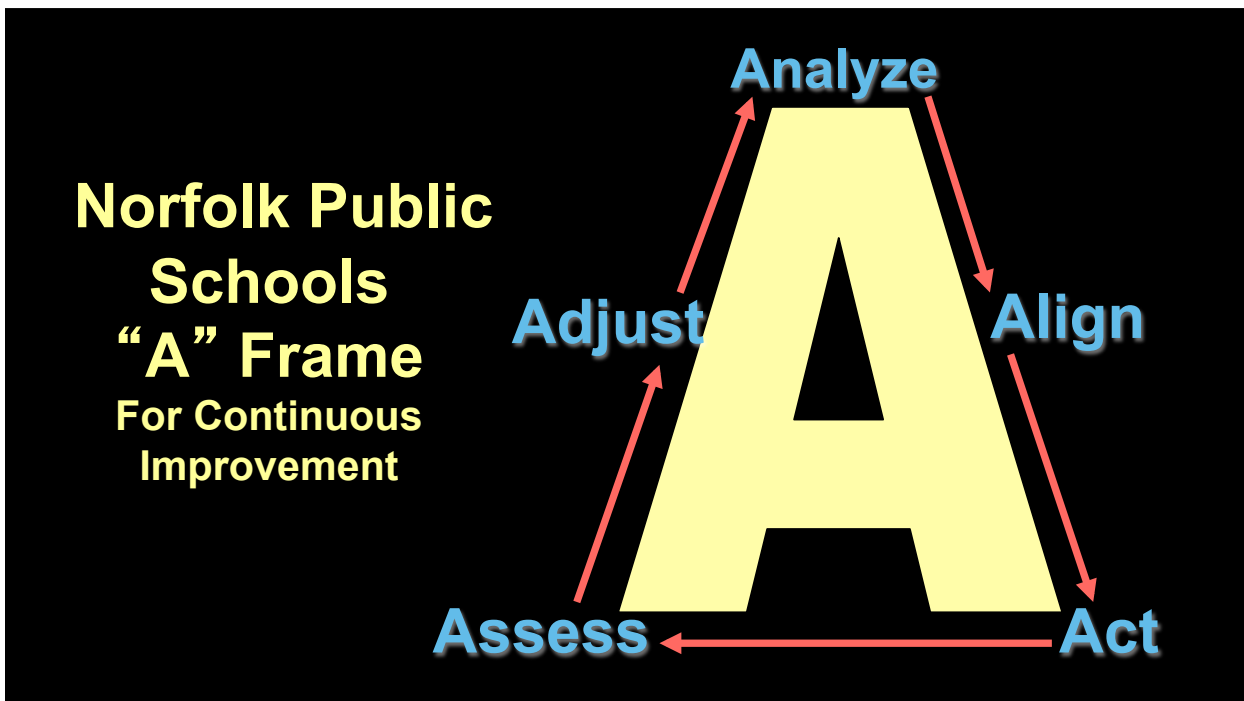
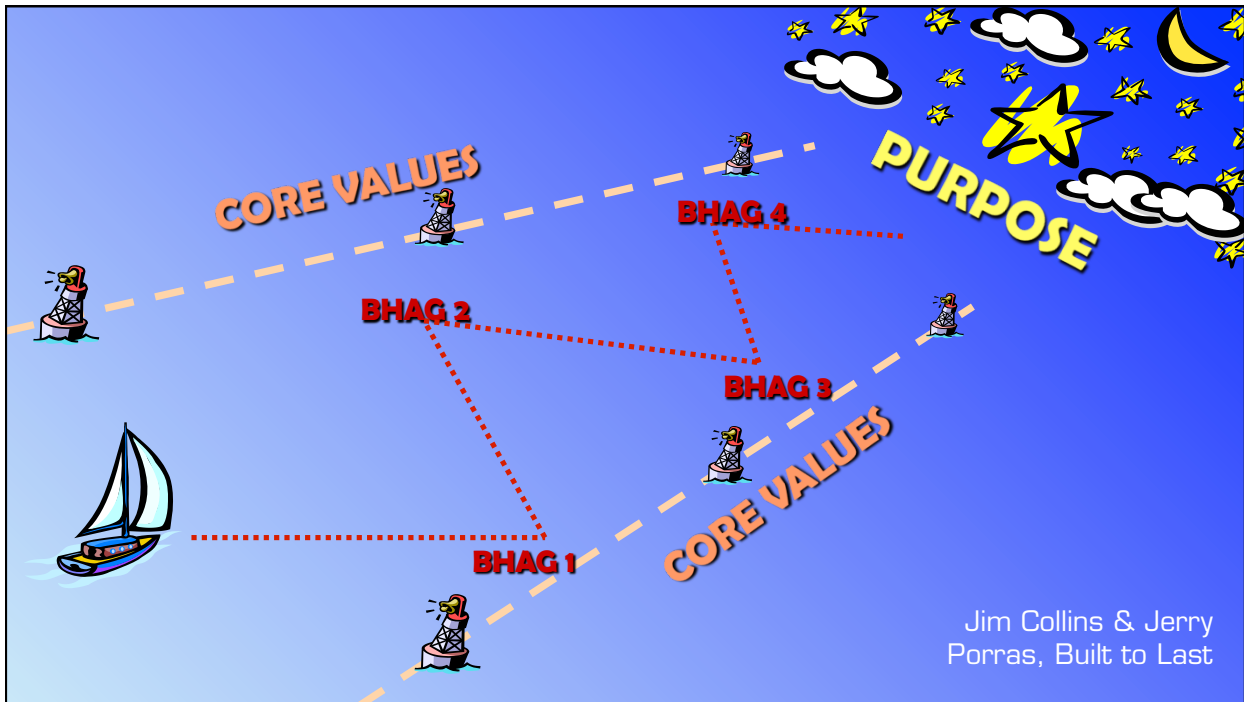

Think beyond the single slide

Expand your canvas via transitions & animations

animation

shortened path

animation

shortened path

animation

An Alternative to Slides



www.prezi.com







Questions

Vincent Rhodes, PhD, APR
varhodes@gmail.com
@varhodes

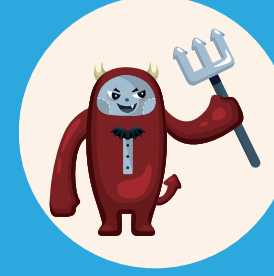

Good *Bad* *Ugly* *Effective*



Getting the Most Out of Presentation Software

Vincent Rhodes, PhD, APR
varhodes@gmail.com
@varhodes



An Alternative Presentation Style

O'REILLY
OPENSOURCE
CONVENTION

Keynote
Identity 2.0
Dick Hardt
Founder and CEO | Sxip Identity